



MITSUBISHI ELECTRIC AUTOMATION (THAILAND) CO., LTD.
 Bang-Chan Industrial Estate No. 111 Moo 4, Serithai Rd., T.Kannayao, A.Kannayao, BKK 10230 Thailand
 Tel: (66) 2517-1326, (66) 2919-9873 Fax: (66) 2517-1328 URL: www.meath-co.com E-mail: support@meath.co.th
บริษัท มิตซูบิชิ อิเล็กทริก ออโตเมชัน (ประเทศไทย) จำกัด
 นิคมอุตสาหกรรมบางชัน เลขที่ 111 หมู่ 4 ถนนเสรีไทย แขวงคันทนาয়াว เขตคันทนาয়াว กทม. 10230
 โทรศัพท์: (66) 2517-1326, (66) 2919-9873 โทรสาร: (66) 2517-1328 URL: www.meath-co.com E-mail: support@meath.co.th

MOTOR SPECIFICATION SHEET

MODEL : SF-PRV 11kW 4P
 USED FOR : 380V 50Hz
 MANUFACTURER : MITSUBISHI ELECTRIC CORPORATION

DESCRIPTION	DETAIL
PHASE	3
MODEL NAME	SF-PRV
RATED OUTPUT	11 kW
POLE	4
CODE	
OUTLINE DRAWING NO.	BD39186-*
RATED VOLTAGE (V)	380
RATED FREQUENCY (Hz)	50
RATED CURRENT (A)	21.5
RATED SPEED (min ⁻¹)	1460
RATED EFFICIENCY	92.3%
EFFICIENCY CLASS	IE3
THERMAL CLASS	130 (B)
RATING	S1 (CONTINUOUS)
ENCLOSURE CONSTRUCTION	TOTALLY ENCLOSED FAN COOLED
DEGREES OF PROTECTION	IP44
METHOD OF COOLING	IC411
FRAME NO.	160M
WEIGHT (kg)	110
STANDARD	JIS C 4213, JEC-2137-2000
INSTALLATION	FLANGE MOUNTED (VERTICAL)
ROTATION	CCW (VIEWED FROM SHAFT END)
BEARING	LOAD SIDE : 6309ZZ OPPOSITE SIDE : 6308ZZ
BEARING GREASE	UREA GREASE
NOISE (dB.A)*	64
VIBRATION	V15
CIRCUMSTANCE CONDITION	AMBIENT TEMPERATURE : -30 ~ +40°C AMBIENT HUMIDITY : 100% RH (NO CONDENSATION) ABOVE SEA LEVEL : 1000m OR BELOW ENVIRONMENT : NO CORROSIVE/EXPLOSIVE GAS, NO STEAM OR CONDENSATION, MINIMAL DUST.
COLOR	MUNSELL N7 (GRAY)
TERMINAL BOX	NO. OF LEAD WIRES : 6 SOURCE CONNECTION : LEAD WIRES
SHAFT SWING	≤0.05mm
MATERIAL	FRAME : STEEL PLATE BRACKET LOAD SIDE : CAST IRON OPPOSITE SIDE : ALUMINIUM SHAFT : CARBON STEEL STATOR CORE : ELECTRICAL STEEL WIRE : ENAMELLED COPPER MAGNET WIRE ROTOR CORE : ELECTRICAL STEEL CONDUCTOR : ALUMINIUM TERMINAL BOX : STEEL PLATE PAINTING : ACRYLIC RESIN
PRODUCTION COUNTRY	JAPAN

*Value indicates representative value, not guaranteed value.

Specifications subject to change without notice.

SPECIFICATION SHEET NO.				
SS-M-3652-A				

TYPE SF-PRV SUPER-LINE THREE PHASE INDUCTION MOTOR

OUT LINE
DIMENSION IN mm

INDOOR USE TYPE

TOTALLY ENCLOSED FAN COOLED
PROTECTION DEGREE IP44 , COOLING METHOD IC411
FLANGE NO. FF300 FRAME NO. 160M

CUSTOMER

USER

FOR

CUST'S ORDER NO.

QUANTITY

UNIT (S)

MFG ORDER NO.

YOUR ORDER	kW·POLES	VOLT	HERTZ	MASS kg/UNIT	STYLE NO.
	11kW 4P	380V	50Hz	110	

IE Code-Rated Eff	
11kW 4P	IE3-92.3%

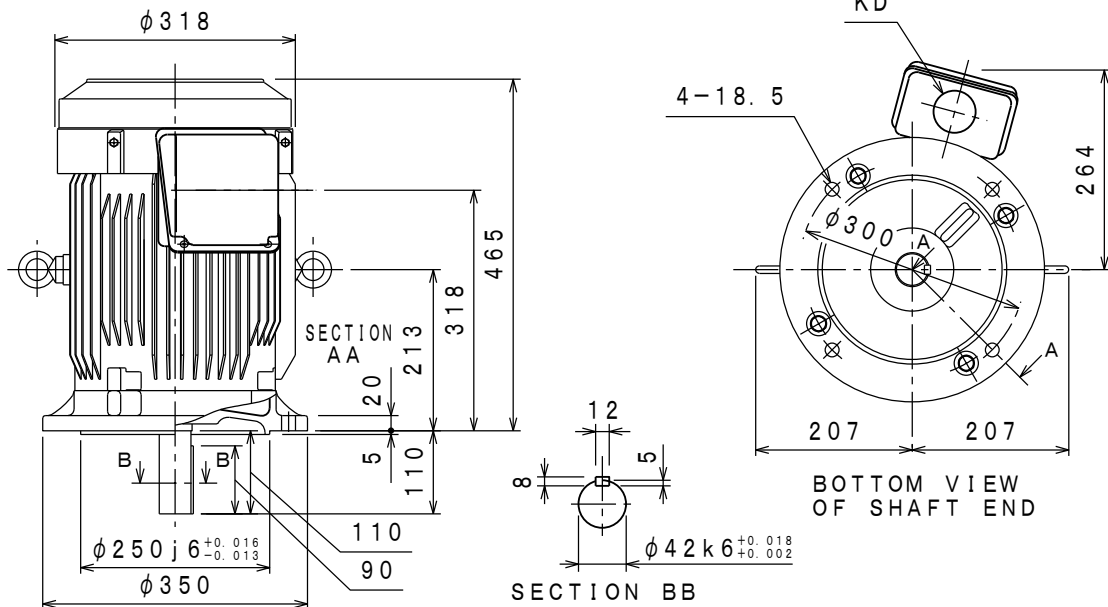

RATING	TH. CLASS	AMB. TEMP	BEARINGS		NO. OF TERMINALS	VIEWED FROM DRIVE END		COLOUR	KD
			LOAD SIDE	OPPOSITE SIDE		DIRECT. OF TERMINAL BOX	ROTATION		
S1	130 (B)	40° C	6309ZZ	6308ZZ	6	-	CCW	MUNSELL N7	φ56

<和文: BD27490>

MITSUBISHI ELECTRIC CORP., JAPAN
NAGOYA WORKS

CHANGE			
--------	--	--	--

	DRAWN	APPROVED
SCALE NTS		
DATE FEB. 15. '19		

CAD(2D)

図面
番号
DWG.
NO.

BD39186-*